

Movement Joints: MJW6

Renderplas

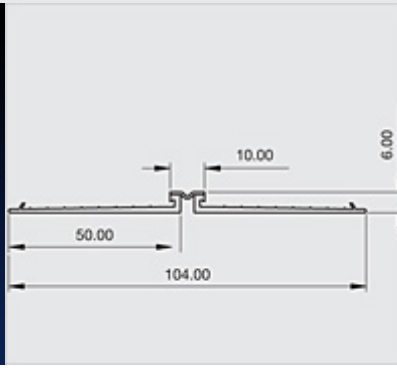

Locally manufactured from recycled plastic, Renderplas PVCu movement joint / expansion joint beads are designed for areas of render over 20 square metres and should be specified every 4-6 metres, over structural movement joints and changes of background. Discreet but strong, all beading gives a perfect finish to through colour render and is equally suitable for sand and cement

Performance: design data

Affiliations	Federation of Plasterers and Drywall Contractors	Fire	Class 1Y. Combustible within fire source, self extinguishing upon removal of flame, will not contribute to the combustion of the system
Applications	Horizontally or vertically on all standard rendering applications, external wall insulation systems, timber frame; as a day joint to divide rendered sections; at changes to background material	Health and Safety	PVCu beads are safe to handle removing the dangers of cut metal; suitable for prisons and schools
Chemical	Zero chemical reaction with water, sand and cement, acrylic render, water based paint; avoid organic solvents, chlorate bleach, strong acids and alkalis	Heat	Ideal for all habitable climates; eliminates cold bridging
Durability	Impact resistant; dissipates shock waves; outlasts metal; cleaned in same way as render	Guarantees	Fit for purpose for the lifetime of the render and at least 25 years
Economics	PVCu beads are a fraction of the price of stainless steel; added value over galvanized steel as PVCu beads are guaranteed not to stain or corrode and can reduce installation time. Reduction of impact damage	Mechanics	Flexible plastic membrane gives a certified range of +/- 1.5mm which meets British Standard for thermal movement (BS EN 13658-2:2005). Protective tear off strip allows quick removal of render from the joint
Environment	Locally manufactured; high recycled content; fully recyclable; low Ecopoint score of 0.004/kg delivered	Pollution	Ecologically benign; non-hazardous in water; non-hazardous if ingested; does not release substances into the atmosphere
		Strength	PVCu beads offer sufficient strength for these applications. The chemical bond between flexible and rigid parts prevents separation
		Weather	Flexible plastic membrane provides a watertight seal. Not affected by weather and should be specified in all regions of high moisture or high salt

Specification: standard data

Type	MJW6	Weight (kg/100m)	16.8
Authority	BBA certified; manufactured to ISO 9001:2000; complies with BS EN 13914-1&2:2005 and BS EN 13658-2:2005; fire tested to BS 476; complies with REACH	Stock Colours	White, Brick, Dove, Ivory, Maize, Peach, Salmon, Sky, Slate, Terracotta, Wheat, Willow
Brand Names	Renderplas	Length	2.5m
Description	6mm PVCu Wide Wing Movement Joint Beads (Expansion Joints)	Packaging	6 lengths in triwall fibreboard box
Composition	Exterior grade impact resistant UV stable unplasticised PVCu	Format	Cut lengths
Dimensions (mm)	9mm exposed width and 50mm wings each side	Recycled Content %	93.0%
Depth (mm)	6mm render depth	Light	UV stable; any discoloration is uniform over a single facade and within industry standards

Site works

Installation	Standard industry practice and tools can be used. Large irregularities in the substrate should be dubbed out and allowed to set hard prior to application. Cut to length with tin snips or fine tooth saw. Non-corrosive mechanical fixings can be used to fix the beading to the substrate without the need for render or mortar. Fixings should be at 300-700mm centres, at the high points if the substrate is uneven	Storage	Store vertically out of direct sunlight or extreme temperatures. Can be stored flat if supported along entire length
		Supply	Ex-stock next day delivery to site through extensive supply chain or direct from www.renderplas.co.uk

