

## EPNR-R

### EPNR-R External Performance Stair Nosing

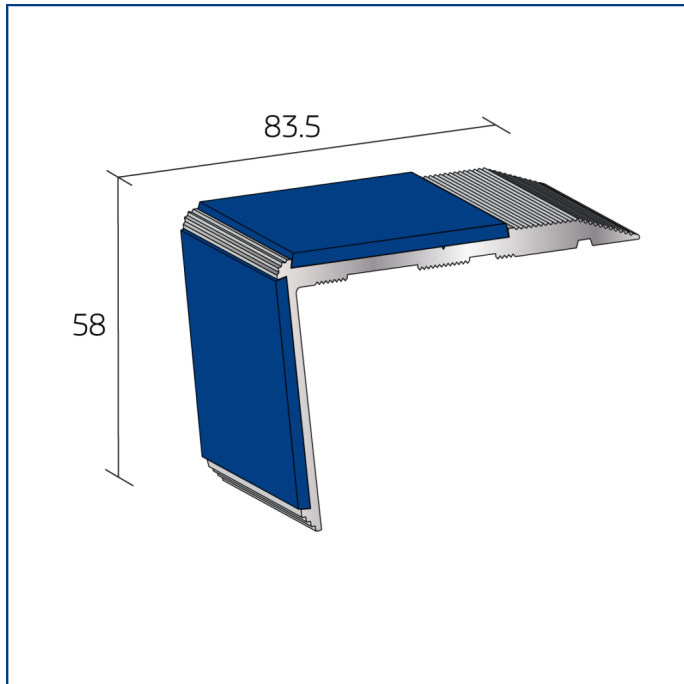

## SPECIFICATIONS

<b>Material</b>	Aluminium
<b>Height (mm)</b>	58
<b>Width (mm)</b>	83.5
<b>Gauge (mm)</b>	Surface mounted
<b>Fitting Method</b>	Drilled and Plugged
<b>Environment</b>	External or Internal
<b>Use with</b>	Surface mounted
<b>Channel</b>	Heavy Duty
<b>Insert types</b>	Standard, EcoGlo, Plus-Tread
<b>Warranty</b>	10 Year (On application)
<b>Building Reg Compliant</b>	Yes
<b>Equality Act Compliant</b>	Yes
<b>Standard length</b>	Cut to size
<b>Cuts as required</b>	Yes
<b>Finishes</b>	Standard Mill
<b>Tread width (mm)</b>	50



## LRV & COLOUR

### Standard Tread

6 Black	6 Claret	10 Peat	10 Rustic	11 Dark Blue	11 Granite
11 Regency	11 Spruce	13 Poppy	15 Flint	16 Royal Blue	21 Fawn
26 Light Grey	30 Jade	33 Tangerine	49 Polar Grey	51 Ivory	52 Sky
53 Lime	56 Sun	64 Mist	67 Yellow	77 Desert	81 White

### EcoGlo Tread

5 Black	49 Yellow	69 Photoluminescent
---------	-----------	---------------------

### Plus Tread

5 Carbon	9 Ruby	22 Aqua	27 Platinum	41 Sand	47 Hornet
----------	--------	---------	-------------	---------	-----------

These colours are for guidance only, always [request a sample](#) for an exact colour match. [Read more about Light Reflectance Values \(LRVs\) here.](#)

## EPNR-R

### EPNR-R External Performance Stair Nosing

**Text Specification Statement: M50/750A - STAIR NOSINGS:**

**Manufacturer and reference(s):** Quantum Flooring Accessories

**Contact:** +44 (0) 161 627 4222 / [quantumflooring.co.uk](http://quantumflooring.co.uk) / [info@quantumflooring.co.uk](mailto:info@quantumflooring.co.uk)

**Material/finish:** EPNR-R

**Inserts:** colour Colour/ Light reflectance value (LRV): EcoGlo Photo (69). EcoGlo Black (5). EcoGlo Yellow (49).

**Fitting:** Drilled & Plugged. Adhesive Only Q-Fix. Secret Fixing.

**Other:** Use the free Quantum measure service for ready to fit stair nosings: Email [info@quantumflooring.co.uk](mailto:info@quantumflooring.co.uk) to book

### FEATURES AND BENEFITS:

**Enhanced safety and compliance:** Provides high slip resistance and colour contrast to support safe navigation in accordance with BS 8300 and Building Regulations Parts M and K, ensuring inclusive and accessible environments.

**Custom sizing:** Nosings can be manufactured to suit any stair width, ensuring seamless integration into new builds or retrofit projects.

**Exceptional slip resistance:** Fitted with the EcoGlo Carborundum insert, delivering a Pendulum Test Value (PTV) of 60+ in wet conditions, offering superior grip in both wet and dry environments.

**Built for heavy traffic:** Constructed from heavy-duty aluminium, these profiles are engineered for high-traffic areas including transport hubs, public buildings, and commercial entrances.

**Outdoor and indoor durability:** Suitable for both exterior and interior applications, performing exceptionally in accelerated UV weathering tests and tested for chemical resistance to ISO 175, ensuring long-term performance even in challenging environments.

**Visual contrast options:** Slip-resistant infills are available in black, yellow, and Photo as standard to provide a high visual contrast against most stair materials, enhancing visibility for all users.

**Finish and installation options:** Available in mill aluminium, and supplied pre-drilled or undrilled to suit different installation requirements.

**Regulatory and industry approved:** Complies with the intent of BS 8300 and packing; see Building Regulations Part M and K. Approved by London Underground, meeting strict performance and safety standards for public transport environments.

**Cost-effective longevity:** A durable and cost-effective long-term solution, reducing maintenance needs and replacement frequency.

**Digital Specification Statement:** [Click here to access all Quantum Flooring Accessories products in NBS](#)