



The SlidePass 2 Soft Close system is designed for wooden wardrobe doors 35 to 45mm thick and up to 930mm wide, supporting loads up to 68kg per door.

Three-wheel hangers with heavy-duty ball bearings ensure smooth, quiet movement, while the versatile design works in wardrobes, bedrooms, kitchens, bathrooms, laundry rooms and offices.

Installation is simple with quick-release locking plates and each kit includes all the hardware for two doors plus a 2m track.

## SlidePass 2

Bypass sliding door system

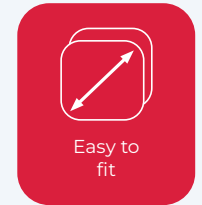
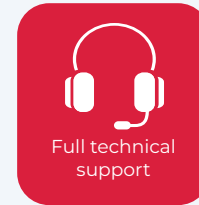
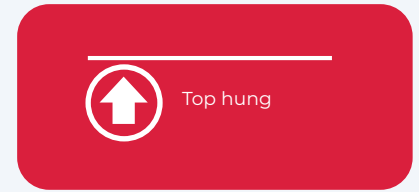

- **Maximum door weight:** 68kg (per door)
- **Minimum door thickness:** 35mm
- **Max door width:** 930mm per panel (two doors)

## SlidePass 2 Components

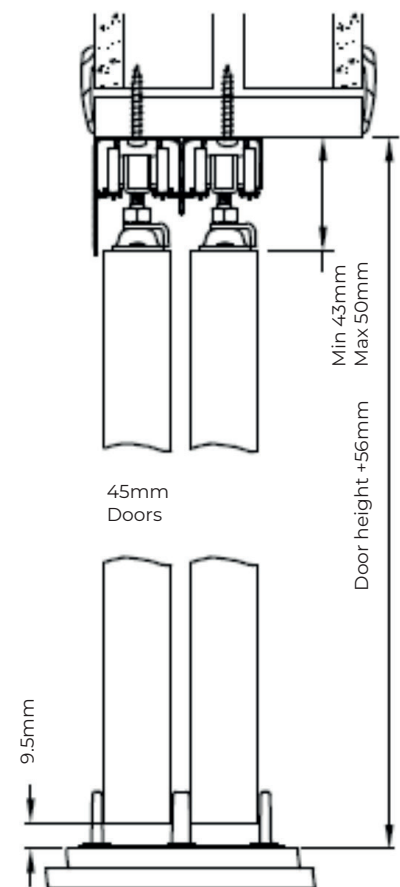
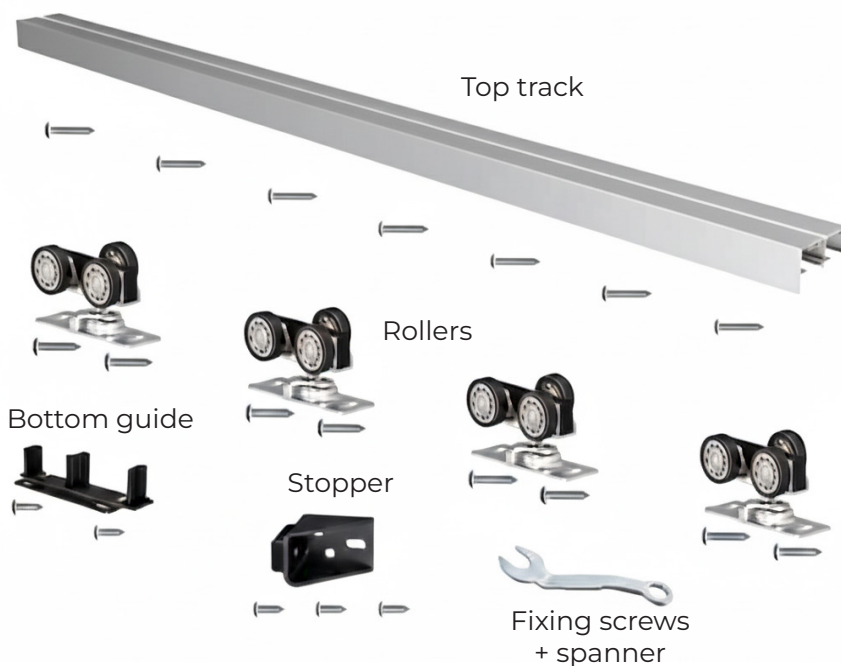

Fitting kit includes:

1 x 2 metre steel track, 2 x three wheel nylon wall roller, 1 x floor guide, 1 x aluminium bottom guide profile, 1 x end cap, fixing screws and spanner